

RAINGEAR

1955-1959 Chevrolet Pick-up Truck

GETTING STARTED: SOME RECOMMENDATIONS PLEASE TRY OUR WAY FIRST!

Note: This system is designed with built in adjustments to fit in 1955-59 Chevrolet pickup truck. If, as you are installing it, you think that you need to modify the parts supplied (except as noted), you are doing something wrong. Please reread the instructions or call us (1-360-385-5493) before proceeding For technical questions, etc., please contact us directly!

Please familiarize yourself with the instructions and drawings that are included. Note that the kit does not include the outside chrome escutcheons (trim bezels) which cover the pivot posts in the cowl. These escutcheons include the washer nozzles which often need to be replaced. Pacific Western Design carries these escutcheons. See price list.

• **First: DISCONNECT YOUR BATTERY** •

(You will be working under the dash in an area of your vehicle, which contains its greatest concentration of electrical wiring.)

- Remove the ashtray, radio and glove box
(the two screws at the top / middle secure the door latch only and do not need to be removed).
- Dismantle the original wiper system. **SAVE ALL OF THE ORIGINAL PARTS.**
- Remove the octagonal nuts from the pivot shafts with a 12 -point 3/4" wrench. Save for later use.
- Remove the rubber hoses from the squirter nozzle tubes at the right and left hand escutcheons.
- Separate the right and left-hand drive links from the drive pins on the original wiper motor.
- Remove the right and left-hand pivot post and link assemblies.
- Remove the stock wiper knob and switch from the dashboard.
(Keep the knob for use with the *Pacific Western Design* system.)
- Remove the original wiper motor.

All motors (1955-59) are attached with two fasteners on the underside of the dashboard sheet metal, the '55-57 has one lower motor brace forward to the firewall and the '58-59 uses two braces.

• **PRE-ASSEMBLY** •

*If you are planning to install a windshield washer pump and reservoir, you will need to shorten the copper squirter -nozzle tube on the right hand escutcheon to about 7/8" to 1" long.
See illustration.*

- Pre-assemble the links to the pivot shafts. The links are made with one end extended about 2" beyond the mounting hole location. This longer "bent" end is attached to the pivot posts. The bushings must be installed correctly oriented to the pivot post and link as shown in the illustration. They are made to be a very tight fit in the link.
- Pre-wire the switch to the motor as shown in the wiring diagram for your switch.

•INSTALLATION•

- Install the passenger side pivot post and link with the rubber gasket on the inside of the cowl, and the pivot post oriented in the upper quadrant (10 o'clock to 2 o'clock) with the outside escutcheon and hex nut included or the original octagonal nut. See illustration.
- Install driver's side pivot post similarly but with the pivot post oriented in the lower quadrant (4 o'clock to 8 o'clock). **IMPORTANT:** You must orient the pivot posts correctly, or you will wipe the hood of your truck instead of the windshield!
- If you are installing a windshield washer system you should install the rubber tubing to the copper escutcheon pipes at this time.
- Install two of the brass spacers through the rubber grommets in the motor assembly and the third one through the grommet in the support bracket.
- Place the motor (with the two grommets oriented upwards and the motor forward), align the bracket with the mounting holes under the dash and fasten with two 1/4-20x5/8" hex bolts and washers.
- Loosely attach the support bracket to the motor bracket as shown and align the grommet on the motor brace with the nut plate on the firewall. Secure with 1/4-20 bolts as shown.
- Push the motor forward until it almost touches the firewall, and secure all of the bolts with the motor about 1/8" to 1/4" away from the firewall so it can't rattle.

The drive arm on the motor should be in the parked position at about 9 o'clock (pointing to the left of the vehicle.) If you want to confirm that it is in the parked position you can wire the motor and switch at this time, turn it on and then off. It will stop suddenly in the parked position.

- Again checking to make sure that the passenger side pivot post is oriented at about 10 o'clock and the drivers side pivot post is oriented at about 8 o'clock, attach the two links to the motor making sure that the bushings are oriented correctly, as shown in the illustration.

Be certain that the rubber hoses from the escutcheons are routed and secured away from the path of levers and links.

- Install wiper switch using chrome bezel nut supplied and your original control knob.

NOTE: Intermittent switch must have ground wire secured or intermittent function will not work correctly.

- Connect the red wire to a 5 amp fused source controlled by the ignition switch.
You cannot use a battery charger to test the system.
- Wire and test operation at this time. Turn the motor off so that it is parked.
- Install wiper arms and blades.

It may be necessary to fine-tune the park position on some vehicles by adjusting the position of the main crank arm on the motor assembly. Use an adjustable wrench to hold the crank arm from turning while loosening the 1/2" nut securing it to the motor. The crank arm should be loose enough on the motor shaft that you can move the wiper arms without any resistance from the motor. Place the wiper arms in the parked position. The crank arm should be approximately 5 degrees below the 9 o'clock position. Tighten the crank arm nut carefully, again using a wrench to hold the crank arm, and make absolutely certain it cannot turn the motor shaft as the nut is tightened.

Figure 1

1955 - 1959 Pick Up

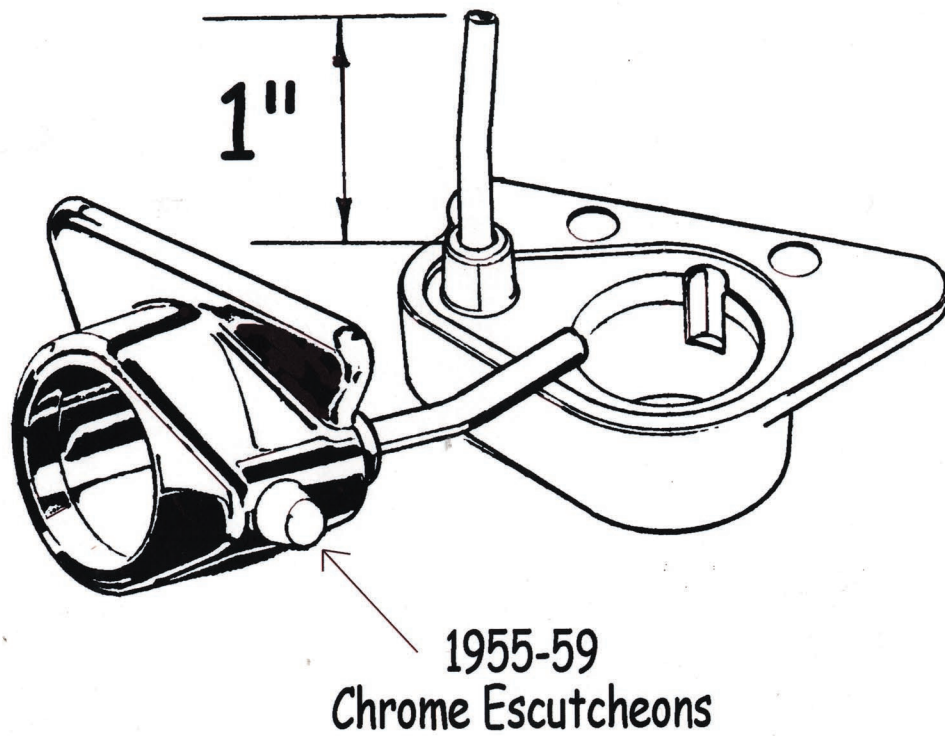

Figure 2

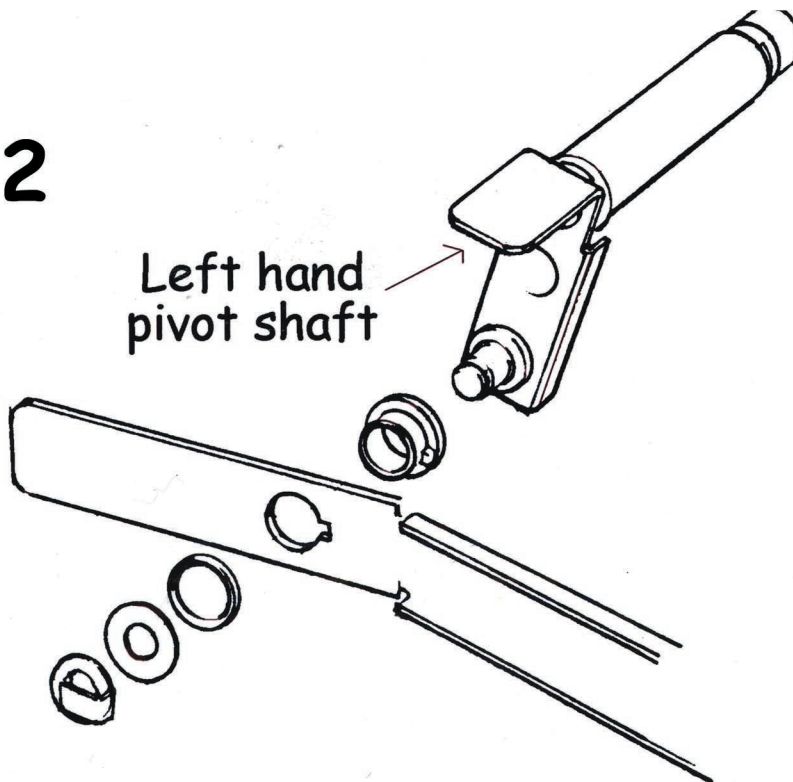

Figure 3

1955 - 1959 Pick Up

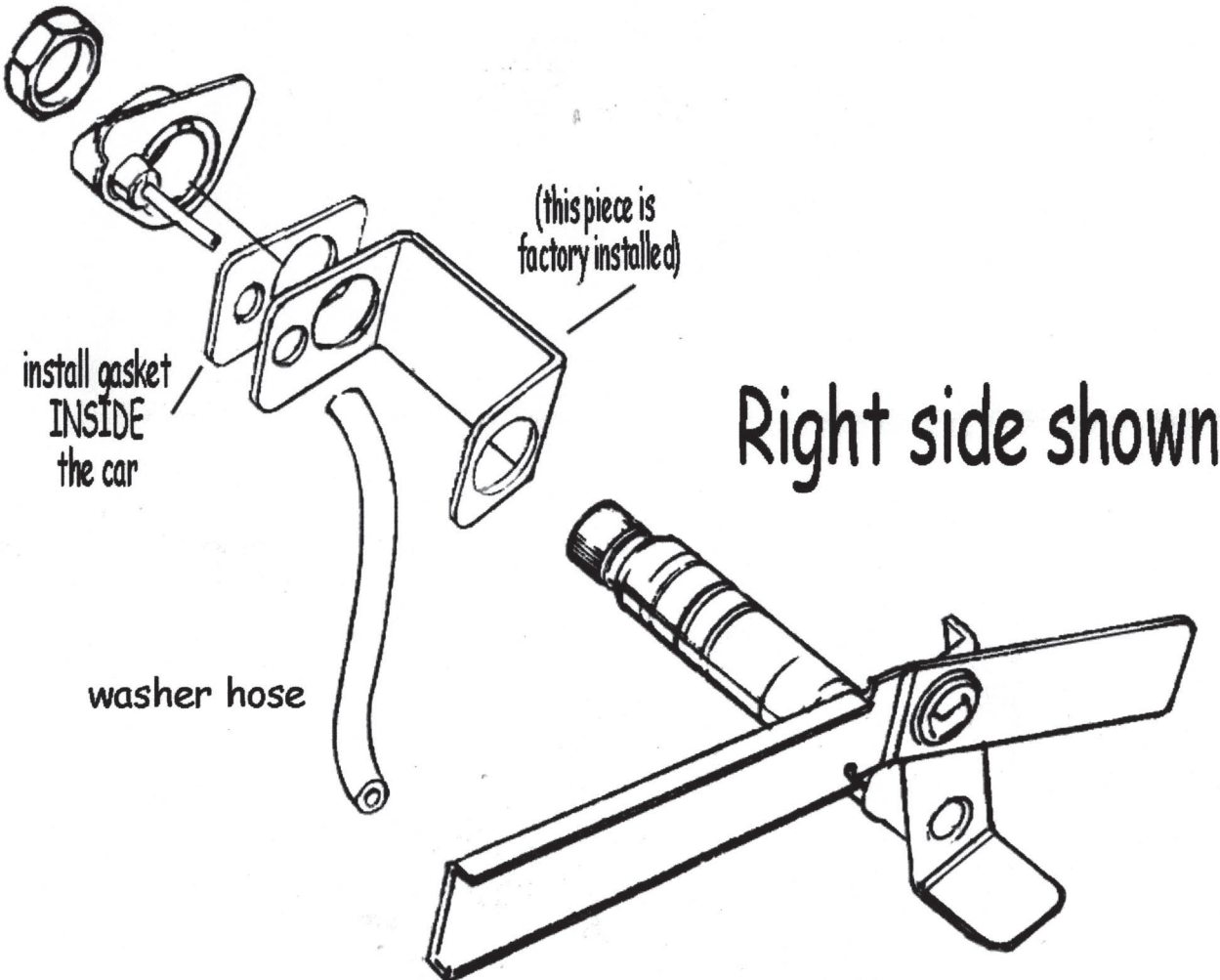
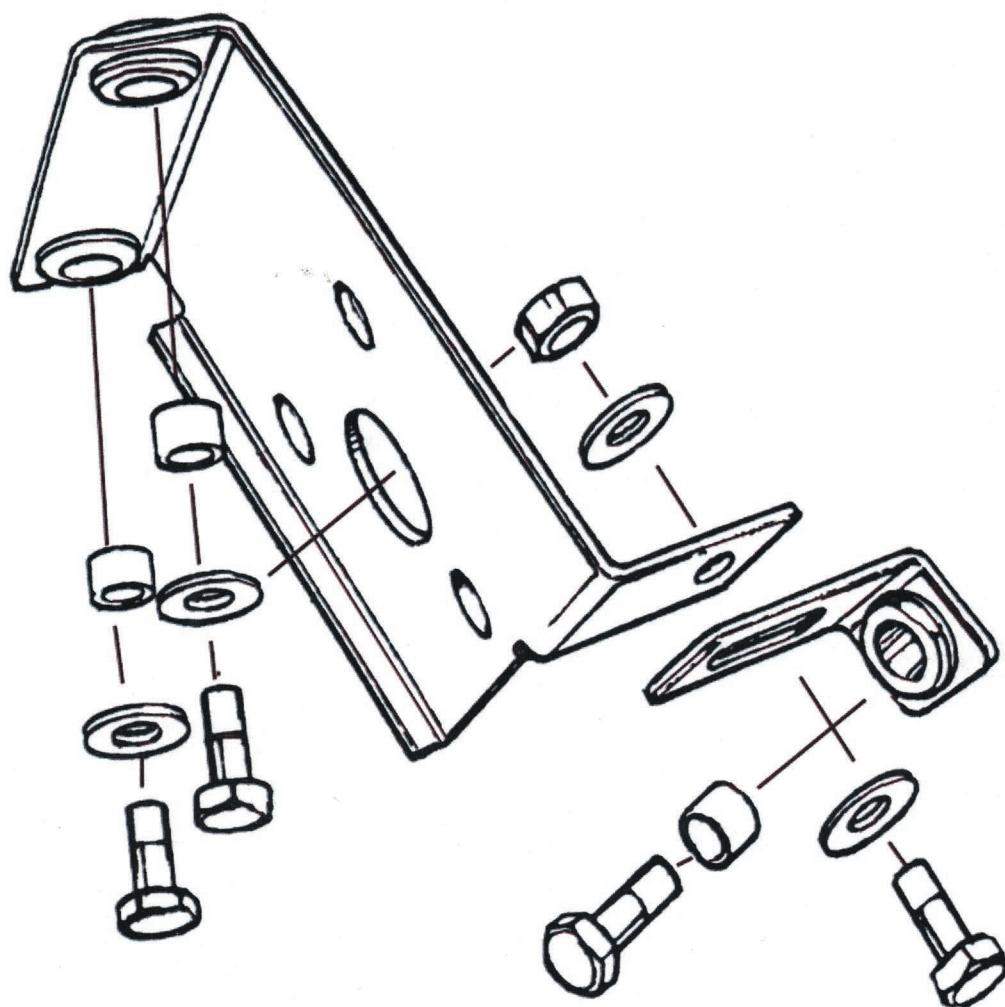

Figure 4

1955 - 1959 Pick Up



Motor Mounting Bracket
(motor not shown)

Figure 5
1955 - 1959 Pick Up

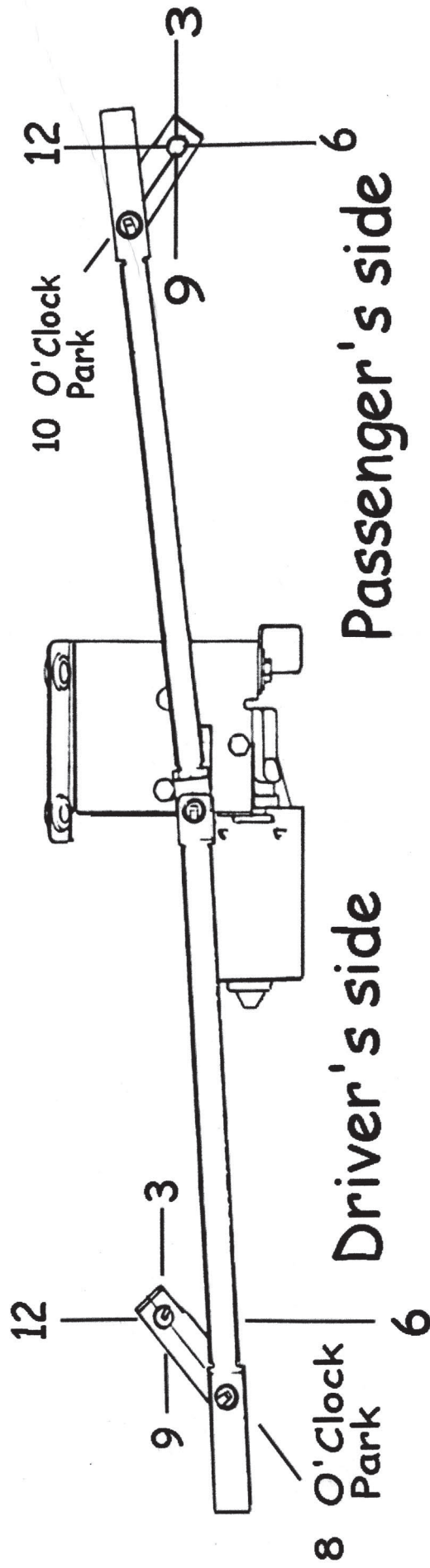
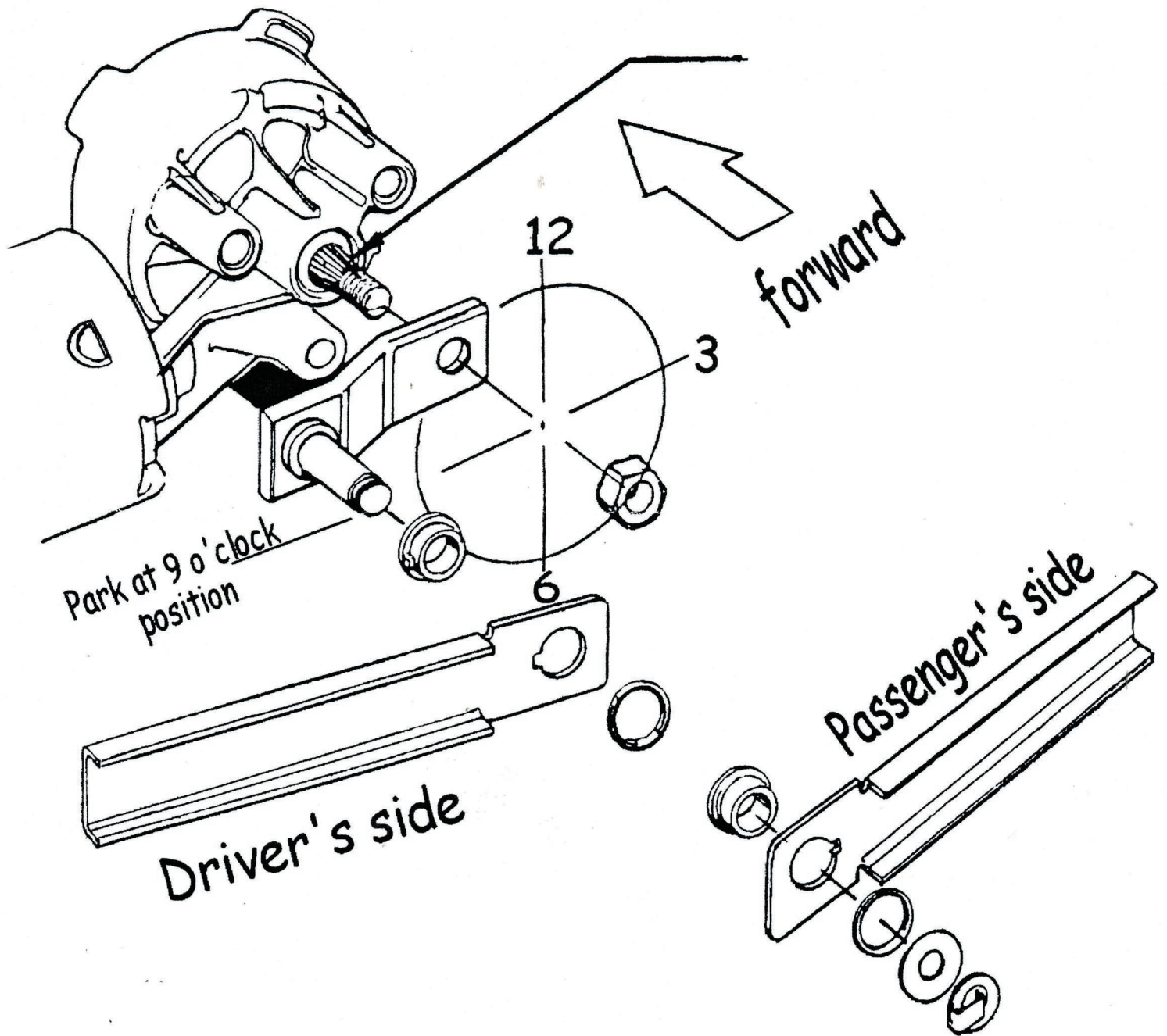

Figure 6

1955 - 1959 Pick Up



RAINGEAR

2 Speed Switch With Washer

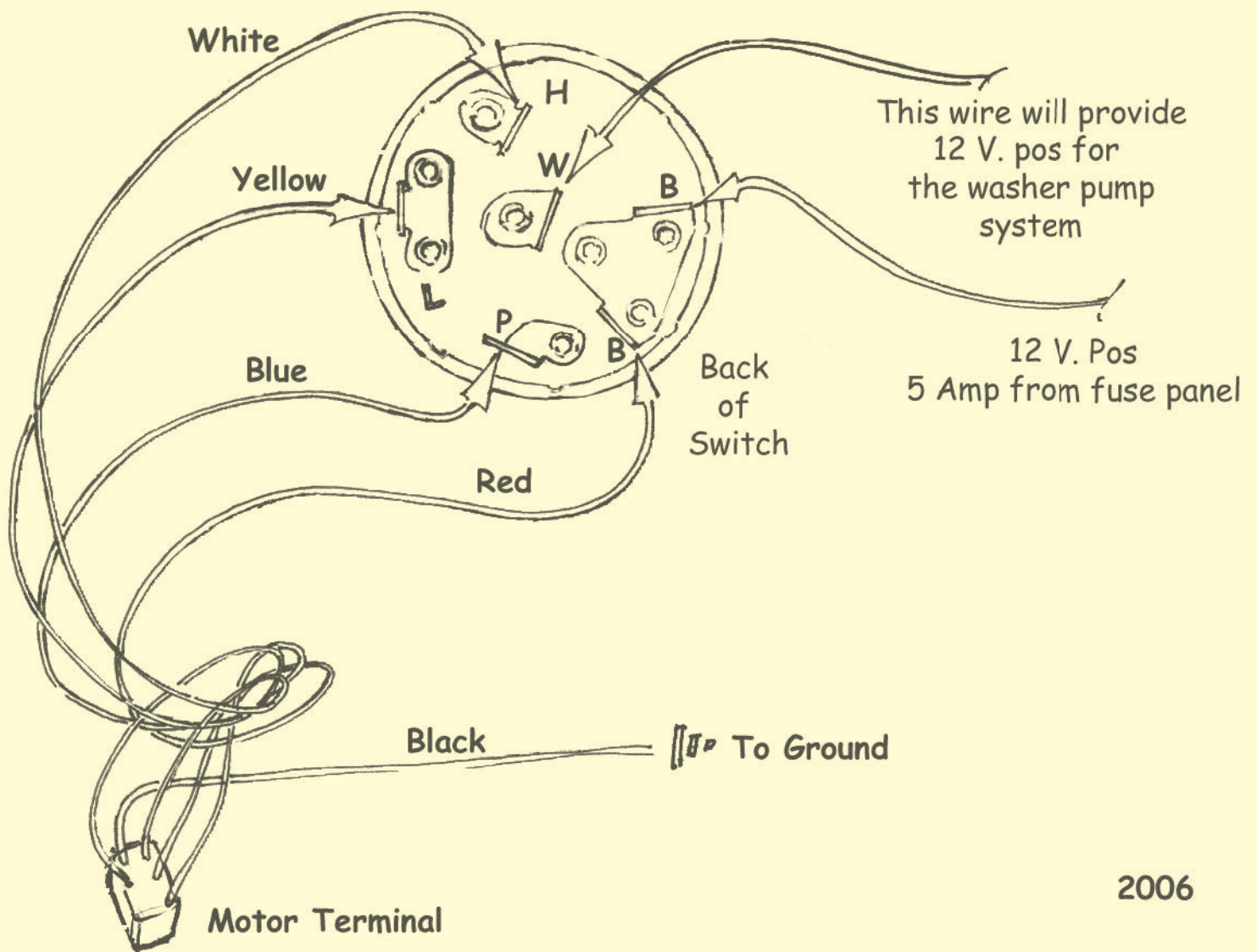
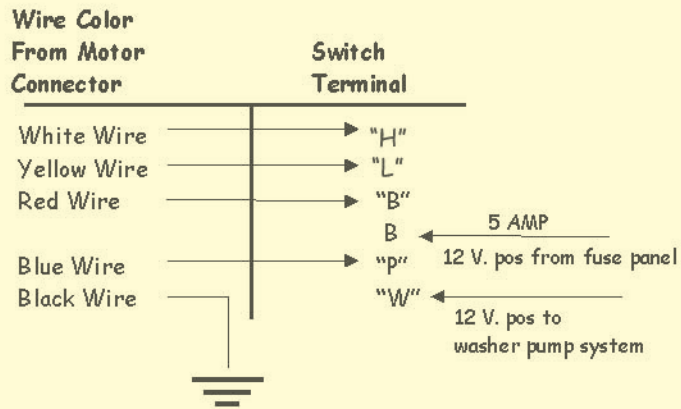

RAINGEAR

2 Speed/Intermittent Switch With Washer

Please Note:
The Intermittent Switch
CANNOT be tested
on a Battery Charger

Turn knob
to adjust the
intermittent
wipe speed

Push knob to
squirt washers -
the wiper blades
will cycle twice

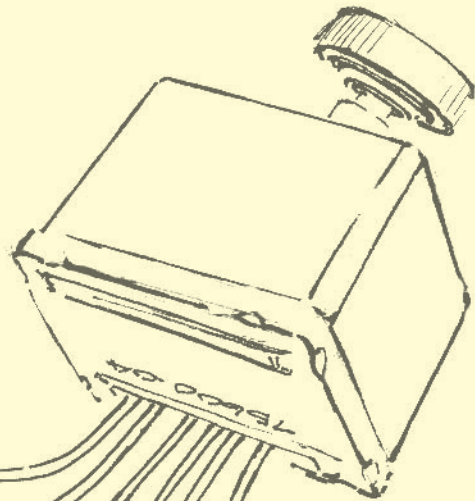

White to White

High

Low

Yellow to Yellow

DELAY SWITCH
MUST
BE GROUNDED



Black

Red

12 Volts, pos
5 amp fuse
from fuse panel

12 Volts, Pos

to Washer Pump System

If washer pump system is not installed,
this wire end must be covered

Brown

Red
to
Red

Blue to Blue

Black wire from motor
connector must
be grounded

Black

