

RetroBelt™ USA

Custom 3-Point Seatbelt Installation Guide for:

1964 - 1975 GM/Chevrolet

Covers most of the following GM models:

Chevelle, Buick, Pontiac LeMans, GTO,
Oldsmobile, El Camino, Chevy Nova,

Camaro/Firebird/Caprice/Impala/Monte Carlo

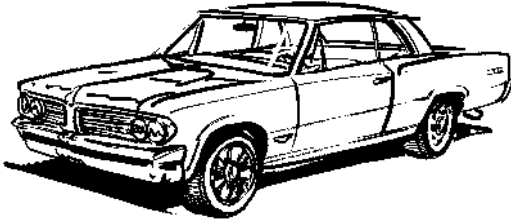
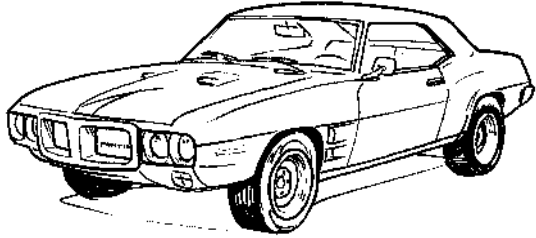

Copyright ©2007 Retro Belt USA, LLC
No text, illustrations or format of this
manual in printed or electronic form
may be copied without written permission
from Retro Belt USA, LLC. All Rights Reserved.

Note: Buick, Camaro, Caprice, El Camino, Firebird,
GM, GTO, Impala, LeMans Monte Carlo, Nova, Oldsmobile, Pontiac
are all registered trademarks of The General Motors Corporation

Note: The information enclosed in this installation guide is to be used as merely an outline to assist you during the process of installation. This guide does not cover every installation possibility, vehicle, or every aspect of the installation process.

RetroBelt USA, Inc, or its subsidiaries, assume no responsibility for a proper or improper installation. Every attempt has been made to make this installation guide as informative as possible, and therefore may be updated from time to time. Please check our website for the latest update. (www.retrobeltusa.com).

Version 1.0
MAY 2007

'64 - '75 GM/Chevrolet Seatbelt Hardware Install Kit

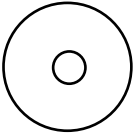

2.48" Diameter
Oversized Fastener/anchor
Qty included: (6) Pcs

RETRO PART # RB-20323



7/16" nut

Qty included: (14) Pcs

RETRO PART # RB-20010



.748" Diameter
Washer

Qty included: (10) Pcs

RETRO PART # RB-20014



1.77" (7/16)

Grade 5 Hex Anchor Bolt
Qty included: (8) Pcs

RETRO PART # RB-20022



7/16"

Nylon Spacers
Qty included: (8) Pcs

RBT-NY-SPC1 & SPC2-20021



7/16" nut

Qty included: (6) Pcs

RETRO PART # RB-20009



1.26" (7/16)

Grade 5 Hex Anchor Bolt
Qty included: (8) Pcs

RETRO PART # RB-20012

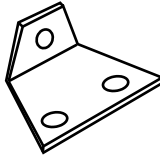

Grade 5
3 way anchor adapter

Qty included: (2) Pcs

RETRO PART # RB-20314

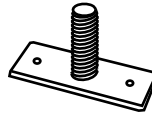

Grade 5 7/16 "T" bolt anchor mount
with solid threaded bolt

Qty included: (2) Pcs

RETRO PART # RB-20312

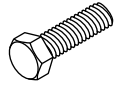

2.25" (7/16)

Grade 5 Hex Anchor Bolt
Qty included: (8) Pcs

RETRO PART # RB-20330



1" Diameter
Washer

Qty included: (10) Pcs

RETRO PART # RB-20021



Grade 5 anchor mount
with 1 threaded anchor holes

Qty included: (2) Pcs

RETRO PART # RB-20304

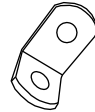

Grade 5 "L" anchor adapter
with 2 anchor holes

Qty included: (2) Pcs

RETRO PART # RB-20305

Note, the installation hardware included in your kit has been put together to cover as many variations of the '64-'75 Chevy/GM vehicles as possible. In many instances your GM vehicle has factory installed anchor points. You may not need all of the supplied hardware. Please search the installation guide for your type of vehicle and feel free to contact us regarding questions you may have.

Note: The information throughout this guide regarding retrofitting is to be used ONLY as a guideline for installing anchor points in vehicles that are not equipped with anchor points. The retrofitting steps in this manual should be performed by professional installers to ensure that the installation is as safe as possible.



'64 - '75 GM/Chevrolet Seatbelt Hardware Install Kit (Install Guide Index Key)

Year & Make/ Model of GM Vehicles: See Page(s):

1964-1973 Chevrolet El Camino	10
1967-1975 Chevrolet Nova	11
1964-1975 Chevrolet Impala/Caprice	3 & 11
1967-1975 Chevrolet Camaro/Pontiac Firebird	3 & 11
1964-1975 GM Buick/Oldsmobile series	3 & 11
1964-1975 Chevrolet Chevelle	3 & 11
1970 -1975 Chevrolet Monte Carlo	3 & 11

***Note:** Most PRE 1967 Chevy vehicles will require drilling & mounting of anchor points and the installation of anchor plates underneath the floor & behind side panels to ensure a safe and secure installation. Retro Belt USA recommends that you have your safety system properly installed.

Please note that if your vehicle is a 1967 GM vehicle and was not equipped with a 3 point system, it was available as an option at the time period, Check underneath the headliner for the factory threads for the shoulder point. This kit uses the "T" bolt to interface to that headliner shoulder point.



Thank you for your purchase of this Retrobelt USA seatbelt product. Your Seatbelt product has been rigorously tested by in independent laboratory to meet or exceed Federal Motor Vehicle Safety Standards (FMVSS) #208,#209 & #302.

Please feel free to contact us via phone or email regarding any further technical questions or support.

LEGAL DISCLOSURE:

RetroBelt USA, LLC, or its subsidiaries, assume no responsibility for a proper or improper installation. Every attempt has been made to make this installation guide as informative as possible, and therefore may be updated from time to time. The retrofitting steps in this manual should be performed by professional installers to ensure that the installation is as safe as possible. Please check our website for the latest upate. (www.retrobeltusa.com).

GOVERNMENT REGULATION INFORMATION:

All US passenger cars, beginning with 1962 models, have seat belt anchorages for at least two lap belts in the front seat area. Since January 1, 1968, vehicle manufacturers have been required to install lap belt anchorages for each front and rear seating position and upper torso belt anchorages at each forward facing outboard seating position. On January 1, 1972, this same requirement became effective for trucks.

IMPORTANT!

Where the vehicle manufacturer has made special provisions to attach belts, be sure to use these fittings.

When you use the manufacturer's threaded floor fittings, it is important that all full threads be engaged to obtain the ultimate strength of the anchorage point.

NOTE:

Seatbelts should NOT be attached to the seat, unless the vehicle manufacturer indicates that the seats and seat mounting systems have been specifically designed to withstand seat belt assembly loads.

PREPARING FOR SEATBELT INSTALLATION:

This custom installation kit will allow you to install most belts for the specified series of vehicle, however there may be some modifications that may need to be made to the vehicle's frame or interior to accommodate a safe anchor point for the belt system.

Determine if your installation is a retrofit (no original seatbelts installed) or if you will be replacing existing 2 point belts and can use some of the existing anchor points. (Note: it is important that wherever you can, to use the factory anchor points, if it is determined that you must make your own anchor points, be sure to check behind or below where you will be drilling for adequate clearance for the bolt and reinforcement plate. Please note, that when drilling you don't accidentally drill into fuel lines,exhaust sytem, gas tank, brake lines, etc. If you have any question that the area you want to anchor to is weak, rusty, or otherwise not suitable, do not use it!

The included hardware kit does include SAE Grade 5 metal anchors and bolts for reinforcement purposes, it is always wise to reinforce an anchor point to ensure the safety of you and your passengers.

Custom Installation guidelines:

Note: This information is to be used as a guideline for installing anchor points in vehicles that are not equipped with anchor points. The retrofitting steps in this manual should be performed by professional installers to ensure that the installation is as safe as possible. Please check our website for the latest updates. (www.retrobeltusa.com) or call us toll free at 888-325-1555.

Where to Install Anchor Points:

Determine if your installation is a retrofit (no original seatbelts installed) or if you will be replacing existing 2 point belts and can use some of the existing anchor points. (**Note:** it is important that wherever you can, to use the factory anchor points, if it is determined that you must make your own anchor points, be sure to check behind or below where you will be drilling for adequate clearance for the bolt and reinforcement plate).

IMPORTANT: When drilling be careful to not accidentally drill into fuel lines, exhaust system, gas tank, brake lines, etc. If you have any question that the area you want to anchor to is weak, rusty, or otherwise not suitable, do not use it! The optional hardware kit does include some SAE Grade 5 metal anchors for reinforcement purposes, it would be wise to reinforce an anchor point to insure the safety of you and your passengers.

Front (Driver & Passenger) Installation guide for PRE- 1967 GM vehicles

1. Set up the Retrobelt system without installing hardware to check placement, remove seats (if necessary), check underneath floor & behind the side panel for ample room for drilling clearance.

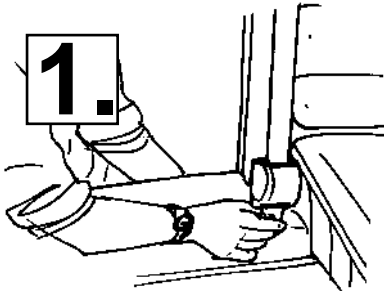

***Note: Most PRE 1967 Chevy vehicles will require drilling & mounting of anchor points and the installation of anchor plates underneath the floor & behind side panels to ensure a safe and secure installation. Retro Belt USA recommends that you have your safety system properly installed.**

Please note that if your vehicle is a 1967 GM vehicle and was not equipped with a 3 point system, it was available as an option at the time period. Check underneath the headliner for the factory threads for the shoulder point. This kit uses the "T" bolt to interface to that headliner shoulder point.

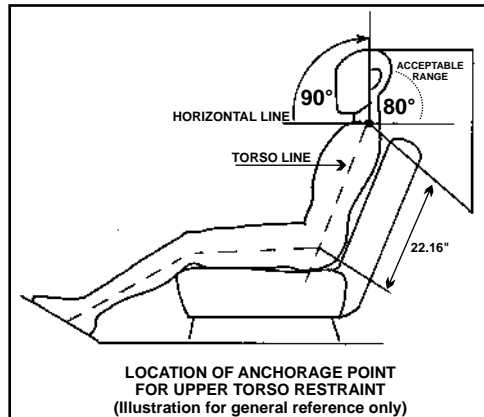

(CONTINUED):

Front (Driver & Passenger) Installation guide for PRE- 1967 GM vehicles

2.

Once the anchor point sites have been chosen, you need to determine that they are solid locations and that you have access behind them.

Line up the retractor and shoulder guides in the desired position for placement. It is critical to make sure that the installation does not interfere with the belt webbing, so the retractor has unobstructed operation for maximum safety.

Make templates out of cardboard for where the retractor & shoulder guide will be mounted and you may need to use one of the included hardware kit's anchor plates as a template for drilling the hole for the anchor point.

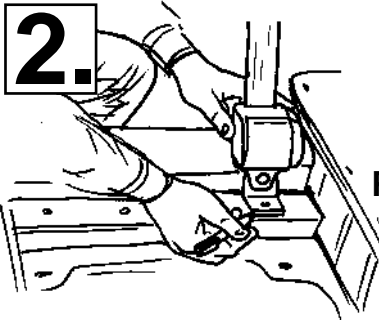

**Trace
for
Placement**

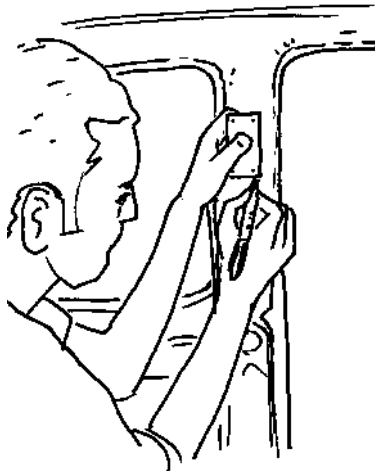
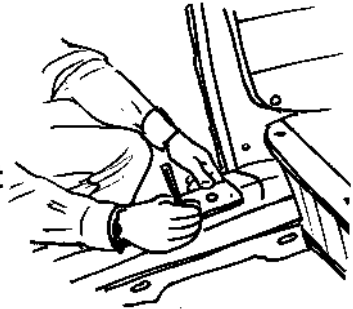

4

(CONTINUED):

Front (Driver & Passenger) Installation guide for PRE- 1967 GM vehicles

3.

This portion of the install guide will provide you with several options for mounting the front shoulder harness of your seatbelt to the "B" pillar post of the car for a safer installation. Since most Pre-1967 Chevy vehicles did not have anchor points drilled in, you will have to make your own anchor points. The most difficult part of the install is mounting the shoulder harness to the "B" pillar of vehicle. Below, and on the following pages are illustrations regarding the steps involved followed by a diagram showing the overall installation and the use of 3 way anchor mount for the retractor, shoulder mount, and belt end of the system.

3.

Installation overview for Front (Driver & Passenger) Pre '67 GM Vehicle

Illustrated overview of installing anchor plate for front shoulder mount for anchor point

Option 1:

After tracing anchor plate outline on pillar, use power saw or other tools to place anchor plate in between metal of "B" pillar/post. use a combination of bolts and rivets to hold plate in place, drill 7/16" hole to allow for mounting of anchor plate to post.

Grade 5 anchor mount
with 1 threaded anchor holes
Qty included: (2) Pcs

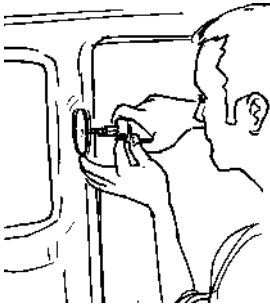
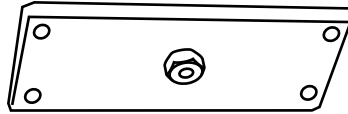

"B" Pillar

Option 1:

Place anchor plate into pillar Use clamps to secure installation

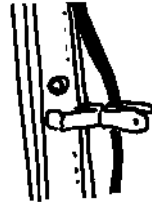
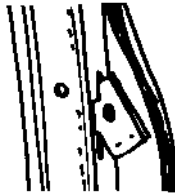
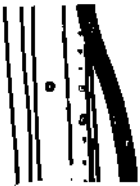

Welding of anchor into the "B" pillar

Option 2:

Weld anchor plate to "B" post, being careful to integrate plate into pillar, this will allow the installation of the shoulder mount to be solidly bolted into the car's frame via the pillar.

NOTE: RetroBelt USA, LLC recommends that this install be performed only by professional and experienced personnel.

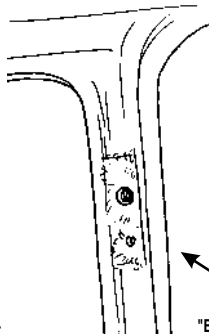

"B" Pillar/post showing anchor mount integrated into metal frame of post.

5

(CONTINUED):

Front (Driver & Passenger) Installation guide for PRE- 1967 GM vehicles

4.

Once Retractor & shoulder guides are in place, install the third mount to the floor using either the existing manufacturer's anchor mount or install a new anchor point using the methods previously described (see illustration below). It is important to make sure that the webbing of the seat belt be tangle free and unobstructed from operation to ensure maximum safety. Once all anchor points have been installed, and belt has been tested, tighten the bolts down and try your new Retro Belt.

Installation overview for Front (Driver & Passenger) Pre-1967 GM Vehicle

Illustrated overview of installing anchor plate for front shoulder mount for anchor point

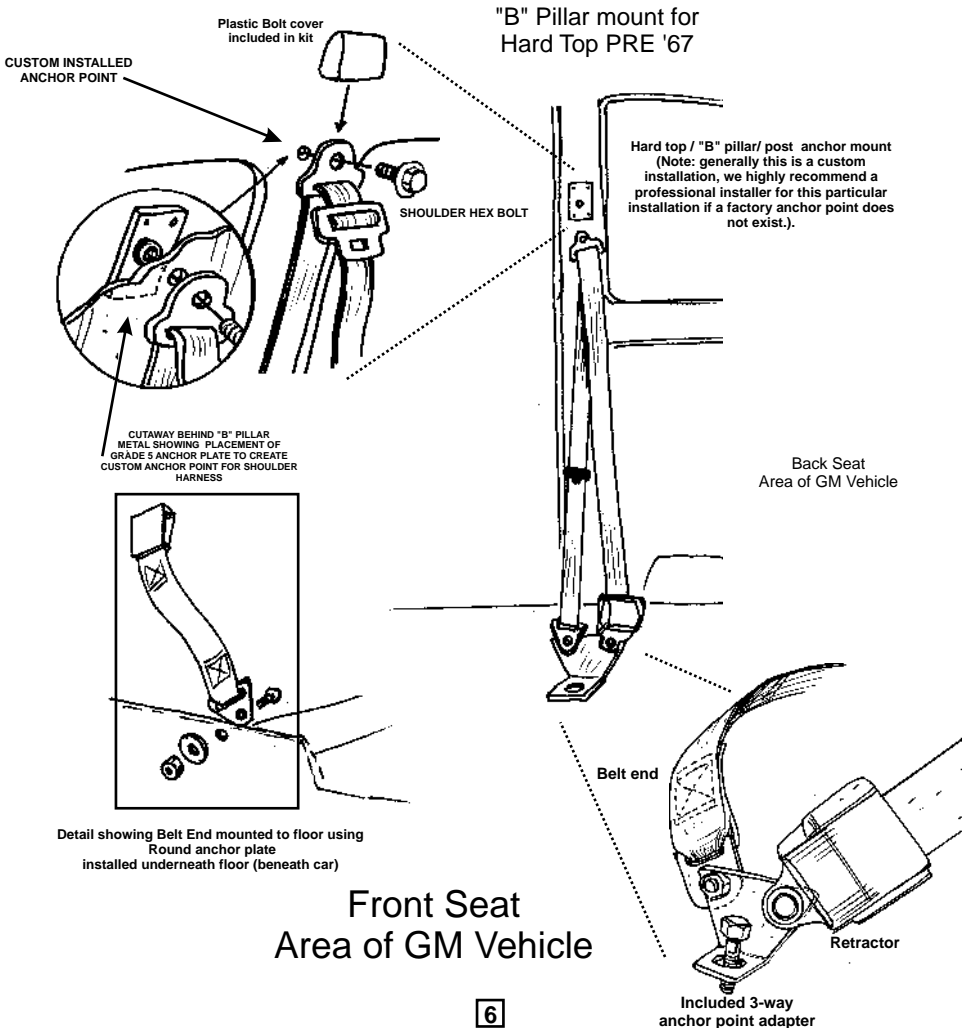

(CONTINUED):

Front (Driver & Passenger) Installation guide for PRE- 1967 GM vehicles

5.

This installation option is for convertible vehicles or 2 door vehicles that don't have a "B" post/pillar. Below is an illustration showing an example of this type of installation. The anchor plate needs to be mounted directly to the frame via a combination of bolts/rivets or welded directly onto the frame of the car below the rear window panel, behind the front driver & passenger seats.

(Note: generally this is a custom installation, we highly recommend a professional installer for this particular installation if a factory anchor point does not exist).

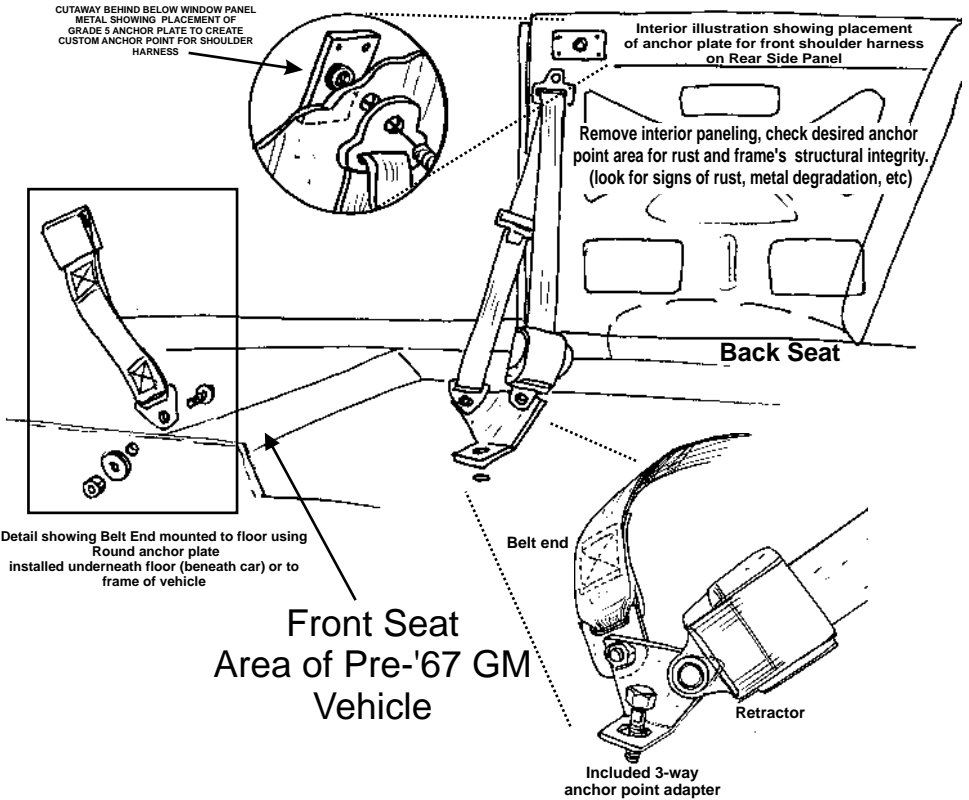

Anchor Point Information Center



Example of no anchor plate installed



With anchor plate installed, maximum safety!

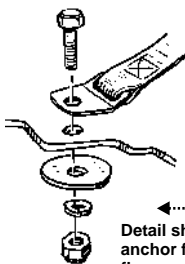

Detail showing use of round anchor fastener for use behind fenders, floors, etc.

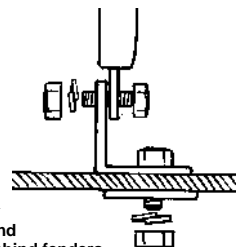

Rear Seat Installation guide for PRE- 1967 GM vehicles using the Retro Belt 2-Point Retractable System

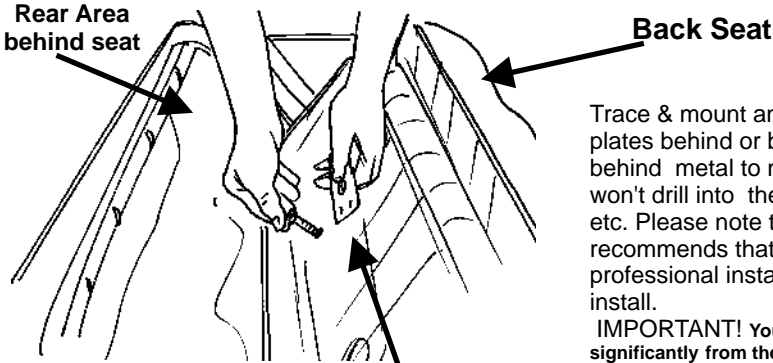

Trace & mount anchor points & anchor plates behind or below the seat. Check behind metal to make sure that you won't drill into the fuel tank, fuel lines, etc. Please note that RetroBelt USA, LLC recommends that this be installed by a professional installer to ensure a safe install.

IMPORTANT! Your GM vehicle may differ significantly from these illustrations, where possible, always mount any anchor portion of a seatbelt directly to the frame of the vehicle or a reinforced portion of the floor or side wall metal.

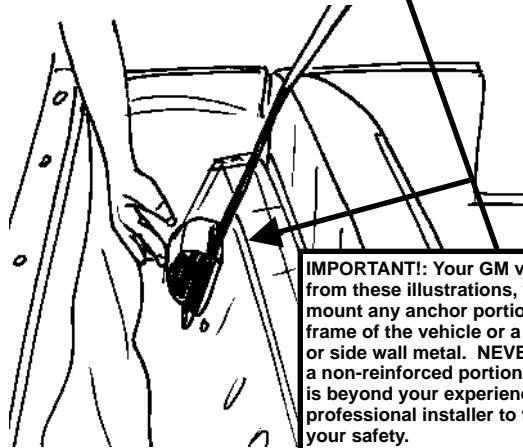

Mount Retractor unit(s) in desired locations to installed anchor points. Be sure to make sure retractor and webbing will be free of entanglement and will operate smoothly.

IMPORTANT! Your GM vehicle may differ significantly from these illustrations, where possible, always mount any anchor portion of a seatbelt directly to the frame of the vehicle or a reinforced portion of the floor or side wall metal. NEVER mount a safety product to a non-reinforced portion of the vehicle. If this install is beyond your experience level, please seek a professional installer to finalize the installation for your safety.

Note: use rear Retro Belt Retractable System for Back Seat Installation, as there is no shoulder anchor used or needed for this type of installation.

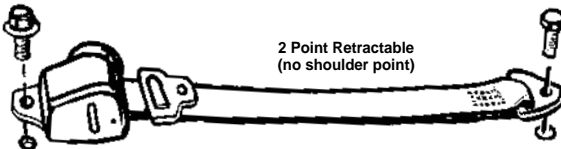

Note: The illustrations on the facing or following pages show the variations available for the installation of the Rear Retro Belt 2 Point Retractable system in a back seat. Please note that whenever possible, mount the anchor on a solid portion of the floor behind the back seat or on the metal frame behind or below the seat. Check underneath the vehicle for clearance and ensure that you won't drill into fuel lines, gas tank, etc. Use similar methods of drilling new anchor points as were used for the front belt installs. Always use the included round or rectangular steel anchor plates to ensure a safe installation. Once installation is complete, install the buckle end to an anchor point, then run the buckle end through the bottom of the seat so passengers have access to the buckle

(CONTINUED) Rear Seat Installation guide for PRE- 1967 GM Vehicles using the Retro Belt 2-Point Retractable System

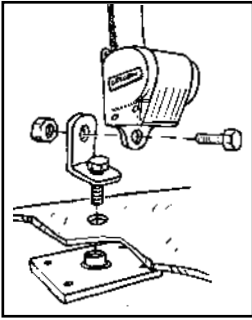

Note:

For this installation, mount the retractor unit behind the back seat on the floor or to the frame of the vehicle directly behind the seat. Use the included anchor plates to ensure that the installation is as solid and safe as possible.

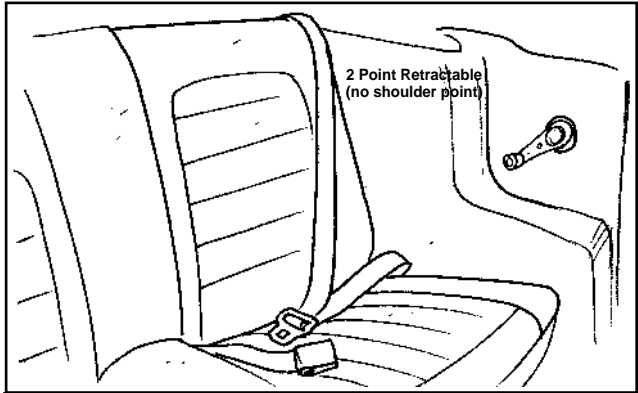

IMPORTANT!: Your GM vehicle may differ significantly from these illustrations, where possible, always mount any anchor portion of a seatbelt directly to the frame of the vehicle or a reinforced portion of the floor or side wall metal. NEVER mount a safety product to a non-reinforced portion of the vehicle. If this install is beyond your experience level, please seek a professional installer to finalize the installation for your safety.

2 Point Retractable
(no shoulder point)

ALTERNATE INSTALLATION OPTION

Note:

This alternate installation option should only be attempted if the rear deck of your GM vehicle is solidly attached to the frame of the vehicle. If you are going for a "stealth" mounting approach, use the installation option above. Use the previously mentioned methods for creating new anchor points to ensure a safe and secure installation.

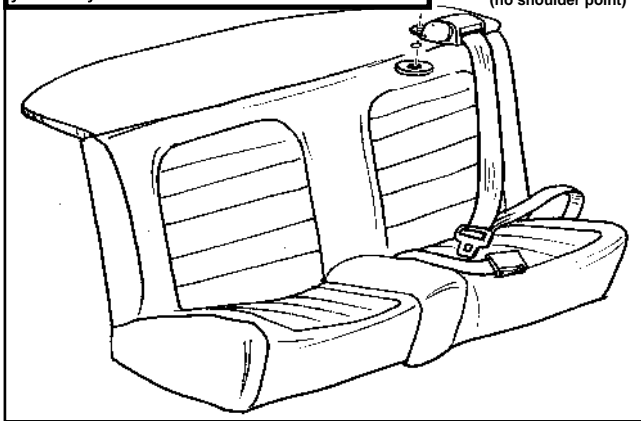

2 Point versus 3 Point: The differences

Due to space limitations for the back seats in these vehicles you may need to consider installing 2 point retractable belts (like the above illustrations) instead of Lap Belts. The difference with these and the 3 point retractables are the inclusion of the shoulder anchor point on the 3 point system. The 3 point belt system has 3 points of attachment to the frame, plus when you buckle in, there's another attachment to the frame for a total of 4 attachments to the frame of the vehicle. The 2 point retractable system has 2 points of attachments to the frame and when you buckle in, that totals 3 total attachments to the frame of the vehicle. --- A simple lap belt only has 2 total points of attachment to the frame when the occupant buckles up.

The 3 types of systems listed in order of occupant security:

1. (Best) 3-point retractable belt system (has a total of 4 attachments to the frame of the vehicle when passenger is buckled in)
2. (Very Good) 2-point retractable belt system (has a total of 3 attachments to the frame of the vehicle when passenger is buckled in)
3. (Good) 2-point Lap belt system (has a total of 2 attachments to the frame of the vehicle when passenger is buckled in)

Installation guide for '64 - 73 Chevy El Camino

Using the original factory location on the floor for the retractor and belt end (see drawing below) use the Retrobelt 3-way triangle floor mount for both items. Use the existing GM roof mount (on '68-'73) or for '64-'67 year El Caminos, you may have to create your own roof mounted shoulder anchor points using some of our included rectangular threaded anchor plates or use the the "T" style anchor (as shown below) and bolt or weld this in to the driver & passenger area just above the shoulder behind the seat to create the shoulder portion of the 3-point system.

Once Retractor & shoulder guides are in place, install the third mount to the floor using either the existing manufacturer's anchor mount. It is important to make sure that the webbing of the seat belt be tangle free and unobstructed from operation to ensure maximum safety. Once all anchor points have been installed, and belt has been tested, tighten the bolts down and try your new Retro Belt.

Installation overview for (Driver & Passenger)

'64- 73 Chevy El Camino (Note: Retrofit instructions will work for 1959-60 El Camino)
Illustrated overview of installing anchor plate for front shoulder mount for anchor point

Note: Mounting angle in illustration may differ from actual vehicle. Please call us if you have any questions.

Included Grade 5 T-Anchor

SHOULDER MOUNTING AREA
 (Use included nut & washer to attach to T-anchor point)

USE EXISTING GM FACTORY ANCHOR POINT WITH INCLUDED RETRO BELT MOUNTING ANCHOR (For 1968-73 El Camino

simply replace current shoulder mount with Retrobelt USA's included "T" anchor, then attach our shoulder anchor point) (NOTE: You may have to modify the T anchors mounting holes in order to use the GM bolts, as GM used different sized bolts during these years.

El Camino Front Seat Installation Example

Area behind seat is the rear deck area, this area has been intentionally left blank.

Use existing factory anchor point to mount retractor unit & bolt end. Use included angle bracket to allow for mounting flexibility.

Closeup detail of 3-way mount for Retractor & belt end

Use existing factory anchor point to mount buckle end. Use included angle bracket to allow for mounting flexibility. Note: if your El Camino is equipped with a Bench Seat, simply feed the buckle receiver through the bench seat between the seat cushion & back rest.

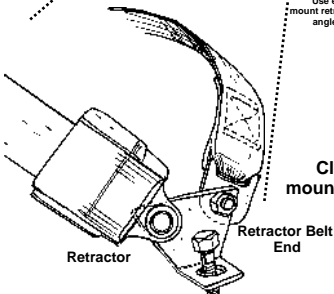

3-Way adapter mounted to floor w/
7/16" bolt

Installation guide for '67 - 75 Chevy Nova, Chevelle, Impala, Caprice, Monte Carlo, Buick, Oldsmobile, Pontiac, Chevrolet Camaro, Firebird, Trans-Am & other similar era GM vehicles

Using the original factory location on the floor for the retractor and belt end (see drawing below) use the Retrobelt 3-way triangle mount for both items. Use the existing GM roof/headliner mount (on '67-'75)

Once Retractor & shoulder guides are in place, install the third mount to the floor using the existing manufacturer's anchor mount. It is important to make sure that the webbing of the seat belt be tangle free and unobstructed from operation to ensure maximum safety. Once all anchor points have been installed, and belt installation has been tested, tighten the bolts down and try your new Retro Belt.

1.

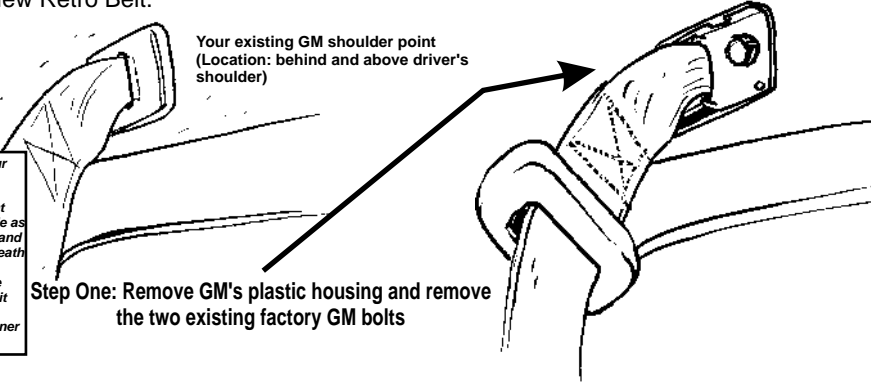

Please note that if your vehicle is a 1967 GM vehicle and was not equipped with a 3 point system, it was available as an option at the time, and you can check underneath the headliner for the factory threads for the shoulder point. This kit uses the "T" bolt to interface to that headliner shoulder point.

2.

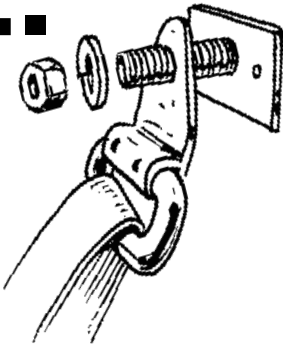

Step 2: Mount the included Retrobelt Grade 5 "T" Bolt Rectangular Anchor using the bolts you removed in step one to attach this anchor to the existing GM location. (Note: you may have to modify the diameter of the "T" bolt's mounting holes to match the various sizes of GM bolts that were used. Attach our shoulder anchor assembly using the supplied nuts and washers, then mount the Retrobelt shoulder anchor assembly to the "T" bolt assembly.

3.

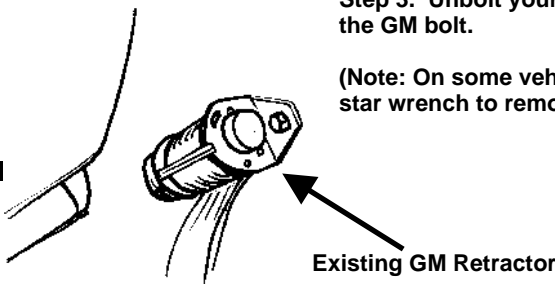

Step 3. Unbolt your existing retractor by removing the GM bolt.

(Note: On some vehicles you may need an allen or star wrench to remove the existing GM retractor bolt.)

Installation guide for '67 - 75 Chevy Nova, Chevelle, Impala, Caprice, Monte Carlo, Buick, Oldsmobile, Pontiac, Chevrolet Camaro, Firebird, Trans-Am & other similar era GM vehicles (Continued)

4.

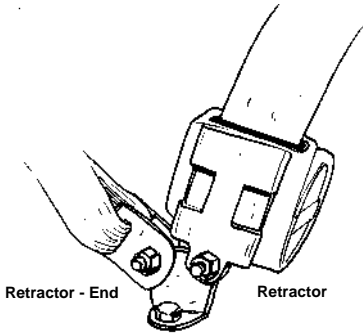

Retractor - End Retractor

Included 3-way Grade 5 anchor point adapter

Step 4: Use the included 3-way adapter and first mount the adapter to the existing GM threaded hole left by the unbolted original retractor from Step 3. Mount the Retro Belt Retractor unit and Retractor end to the 3-way adapter. Please note that the webbing pathway must not be obstructed, so make sure you place the mounting end and retractor assembly to meet your preference to achieve the safest install possible.

5.

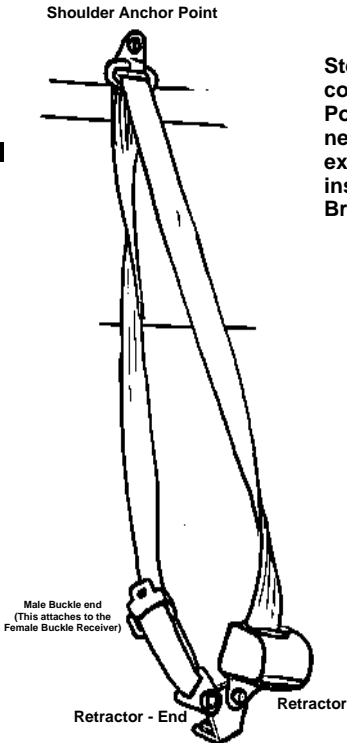

Shoulder Anchor Point

Male Buckle end
(This attaches to the
Female Buckle Receiver)

Retractor - End Retractor

Included 3-way Grade 5 anchor point adapter

Step 5: The illustration on the left shows a completed example of an installed and mounted 3-Point belt system. Please note that you will also need to mount the Buckle assembly using the existing GM anchor point and for maximum installation flexibility, use the included Grade 5 "L" Bracket to mount the buckle end to the floor.



Use & Care of your new seat belt:

1. Always wear your seatbelt, visit www.buckleupamerica.org to learn more about using your seatbelt safely.
2. Adjust and wear the lap belt portion low and tight across your hips.
3. Each belt is intended to restrain only one person at a time.
4. Never attempt to restrain a child in your lap using the 3-point retractable seat belt around both you and the child. The child could be severely injured or even killed in the event of a collision. Please check with your state for local laws regarding the use of safety belts and small children.
5. Do not mix or use this belt or parts of this safety system with other types of seat belts, doing so may result in the belt becoming non operational.

WARNING: FAILURE TO PROPERLY INSTALL, USE, PERIODICALLY INSPECT AND MAINTAIN THIS SEAT BELT COULD LEAD TO SERIOUS INJURY OR DEATH! PLEASE FOLLOW ALL OF THE IMPORTANT INFORMATION BELOW:

Maintenance:

1. Inspect belt and retractor assembly regularly. If the assembly does not work properly or you find cuts, frayed or worn webbing the belt must be replaced.
2. More frequent inspections may be necessary if the belt is subjected to harsh treatment or extreme conditions.
3. Whenever a vehicle is involved in a collision you must replace every part of the seat belt system; both sides of the belt including the mounting hardware!
4. Clean with mild soap and water. Do not bleach or re-dye as it will tend to severely weaken the webbing.
5. Please note that extensive exposure over the years can weaken the webbing on older seatbelts. This effect can reduce the webbing's effective safety feature by over 50%, so it is important to always check your seatbelts periodically for any wear & tear.

CAUTION: DEATH OR SERIOUS INJURY COULD RESULT FROM NOT PROPERLY THREADING THE WEBBING THROUGH THE ADJUSTABLE ENDS. MAINTAIN A MINIMUM OF ONE INCH WEBBING BEYOND THE ANCHOR.

CAUTION: IF THE FIXED END OF A SEATBELT IS TOO LONG TO ALLOW A SNUG FIT ON A SMALL OCCUPANT, DO NOT USE THE BELT! AS A GENERAL RULE, CHILDREN WEIGHING LESS THAN 80 LBS SHOULD BE SECURED IN AN APPROVED CHILD SAFETY/BOOSTER SEAT ACCORDING TO MANUFACTURER'S RECOMMENDATIONS!!!



Warranty:

RetroBelt USA, LLC warrants our products for one year (365 days) from the date of original purchase to be free from defects in materials and workmanship. If, during this period, the product fails under normal usage, because of a manufacturing defect, we will replace or repair the item.

Please note that the retractor and buckle assembly are the only items on the seatbelt that are covered by this limited warranty. The belt webbing and associated hardware are *not covered* under our warranty.

To obtain repair or replacement under the terms of this warranty, please contact us via phone or email (service@retrobeltusa.com) and request a return authorization number. Proof of purchase and date of purchase are required to validate the warranty claim.

If the seatbelt has been involved in an accident, RetroBelt USA, LLC and its subsidiaries cannot be held liable and the seat belt system cannot be warrantied, repaired, or returned.

RetroBelt USA, LLC, or its subsidiaries, assume no responsibility for a proper or improper installation. Every attempt has been made to make this installation guide as informative as possible, and therefore may be updated from time to time. The retrofitting steps in this manual should be performed by professional installers to ensure that the installation is as safe as possible. Please check our website for the latest updates. (www.retrobeltusa.com).

We are not liable for any direct or consequential loss or property damage arising from any use of this product. This warranty gives you specific legal rights, and you may also have other rights, which vary from state to state. Offer good in U.S.A. and Canada only.

RetroBelt™ USA

Custom 3-Point Seatbelt Installation Guide for:

1964 - 1975 GM/Chevrolet

Covers most of the following GM models:

Chevelle, Buick, Pontiac LeMans, GTO,

Oldsmobile, El Camino, Chevy Nova,

Camaro/Firebird/Caprice/Impala/Monte Carlo

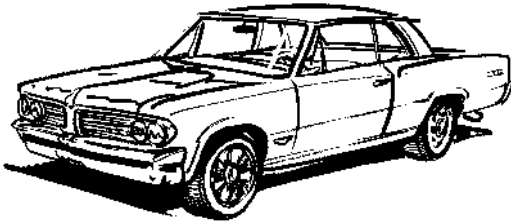
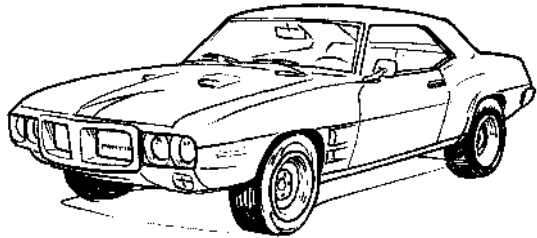

Copyright ©2007 Retro Belt USA, LLC
No text, illustrations or format of this
manual in printed or electronic form
may be copied without written permission
from Retro Belt USA, LLC. All Rights Reserved.

Note: Buick, Camaro, Caprice, El Camino, Firebird,
GM, GTO, Impala, LeMans Monte Carlo, Nova, Oldsmobile, Pontiac
are all registered trademarks of The General Motors Corporation

RetroBelt USA, LLC
13831 Roswell Ave, Unit # J
Chino, California 91710
Phone: 909-364-1372
Fax: 909-364-8670

www.retrobeltusa.com